

# AMERACE AIRPORT LIGHTING Primary Cable Assemblies

<http://www.amerace.com>

<http://www.amerace.com/NewFiles/pcableass.html>



- All connectors are molded on the cable for strong waterproof joints.
- 25 amps
- 5000 volts to earth
- Every cable assembly is continuity checked prior to shipment
- Cable assemblies are conveniently coiled and shipped in boxes or fibre drums (contact factory for reels or other arrangements.)

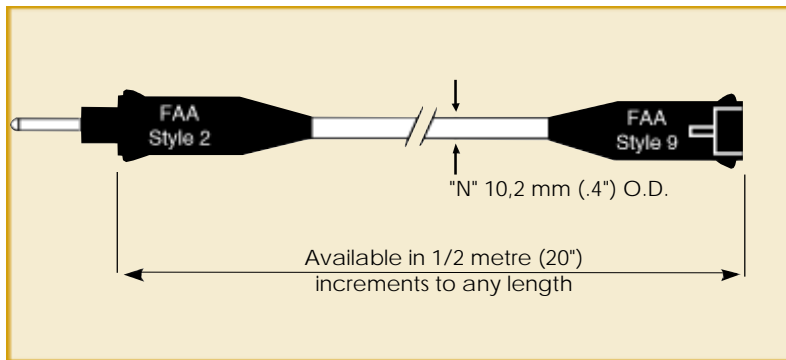

## CATALOG NUMBER CODE

54M - - - - -  
(Length in meters)

**Connector Configuration**  
**P** - Plug (male) connector Style 2  
**R** - Receptacle (female) connector Style 9. If both ends of the cable are to be terminated use two letters here - If only one end is to be terminated, select the correct configuration and use only one letter

**Type of Cable**  
**N** - Single #8 AWG (8.4mm<sup>2</sup>) Type C thermoplastic insulated cable rated 5000V, 25 amp, 90°C (19 strands)

## "T" CABLE

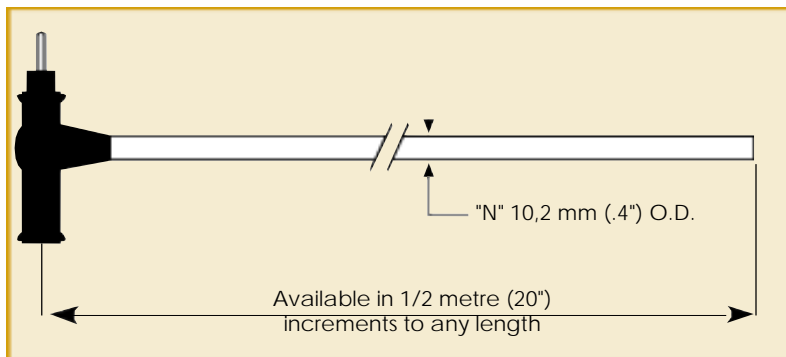

54MT - - - - -  
(Length in meters)

**Type of Cable**  
**N** - Single #8 AWG (8.4mm<sup>2</sup>) Type C thermoplastic insulated cable rated 5000V, 25 amp, 90°C (19 strands)

Note: Also available with Style 2 plug or Style 9 receptacle on free end

# AMERACE AIRPORT LIGHTING Secondary Cable Assemblies

<http://www.amerace.com>

<http://www.amerace.com/NewFiles/ffscable.html>

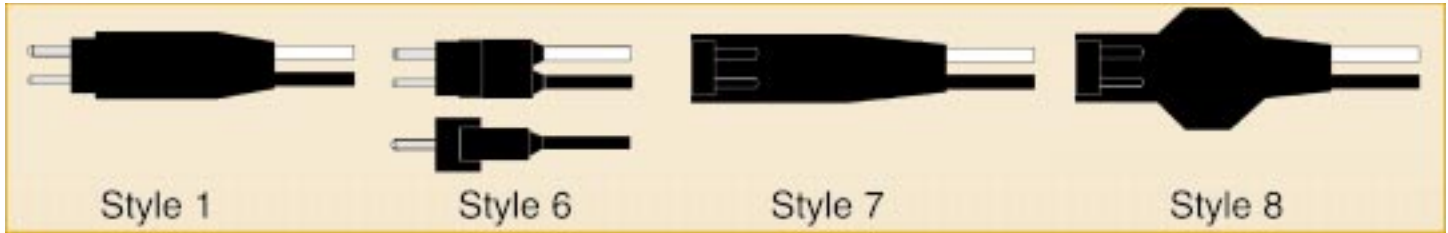

## CATALOG NUMBER CODE

95M - - - - -  
length in meters

### Connector(s)

- P Style 1 Plug
- P6 Style 6 Plug
- R7 Style 7 Receptacle
- R8 Style 8 Receptacle

For connectors on both ends use two codes, otherwise one.

### Cable

- F - Two individual #12 AWG (3,3mm<sup>2</sup>) thermoplastic insulated, waterproof wires, rated 600 volts between contacts, 1500 volts to earth, 20 amp, 90°C. O.D. 4,7mm (.185")
- G - 2/12 AWG (3,3mm<sup>2</sup>) thermoplastic insulated waterproof cable with overall jacket, rated 600 volts between contacts, 1500 volts to earth, 20 amp, 90°C. O.D. 12,7mm (.5")
- H - Two individual #16 AWG (1,3mm<sup>2</sup>) thermoplastic insulated, waterproof wires, rated 600 volts between contacts, 1500 volts to earth, 20 amp, 90°C. O.D. 3,2mm (.125")
- I - 2/16 AWG (1,3mm<sup>2</sup>) thermoplastic insulated waterproof cable with overall jacket, rated 600 volts between contacts, 1500 volts to earth, 20 amp, 90°C. O.D. 9,4mm (.37")
- K - Two individual #14 AWG (2,1mm<sup>2</sup>) Teflon insulated wires, rated 600 volts between contacts, 1500 volts to earth, 20 amp, 200°C, wires certified to UL1199 and CSA1A/B
- L - As K above except #16 AWG (1,3mm<sup>2</sup>)

Available in 1/2 meter increments to any length.

April 2000